

PyroNFC

Operators Guide



The PyroNFC is a non-contact infrared temperature sensor with Near Field Communication (NFC) capability. It has linear voltage and open collector alarm outputs for connection to industrial process instrumentation.

By touching an NFC-enabled smartphone against the back of the sensor, the user can read the measured temperature with a free app. The reading updates continuously while the phone is touching the sensor.

SPECIFICATIONS

Temperature Range	0 to 1000°C
Outputs	Model PN151: 0-5 V DC, 1-5 V DC or 0-10 V DC output, linear with measured temperature, configurable and rescalable via NFC Model PN151-K: Type K Thermocouple output All models: Open collector alarm output with temperature threshold and hysteresis, configurable via NFC
Field of View	15:1 (see OPTICS)
Accuracy	± 1.5% of reading or ± 1.5°C, whichever is greater
Repeatability	± 0.5% of reading or ± 0.5°C, whichever is greater
Response Time, t_{90}	125 ms
Configuration	Via Android app using NFC-equipped device (e.g. smartphone or tablet)
Emissivity	Adjustable via app
Emissivity Setting Range	0.2 to 1.0
Max Temperature Span (Linear Output)	1000°C
Min Temperature Span (Linear Output)	100°C
Spectral Range	8-14 μm
Max. Supply Voltage	28 V DC
Min. Supply Voltage (at Sensor)	12 V DC (for 10 V output) 6 V DC (for 5 V output)
Max Current Draw	7 mA
Warm Up Time (PN151-K)	Allow 10 seconds after power-on before a reading is observed.

ENVIRONMENTAL

Environmental Rating	IP65
Ambient Temperature Range	0°C to 80°C
Relative Humidity	95% max. non-condensing

CONFORMITY

Electromagnetic Compatibility (EMC)	EN61326-1, EN61326-2-3 (Electrical Equipment for Measurement, Control and Laboratory Use - EMC Requirements - Industrial)
RoHS Compliant	Yes

APP

Configurable Parameters	Temperature range Linear voltage output type and scale Alarm output threshold and hysteresis Emissivity setting Reflected temperature
Temperature Units	°C / °F
Signal Processing	Averaging Period (0.125 to 60 seconds) Peak / Valley Hold Hold Period (0.125 to 1200 seconds)
Real Time Temperature Reading	Hold NFC device against sensor for continuous in-app temperature updates

MECHANICAL SPECIFICATIONS

Construction	Black anodised aluminium and ABS
Cable Length	1 metre standard (longer lengths available to order)
Weight with 1 Metre Cable	65 g

ACCESSORIES

Accessories may be ordered at any time and added on-site. The following accessories are available:

Fixed mounting bracket Adjustable mounting bracket Air purge collar

OPTIONS

Options are factory-installed and cannot be retrofitted. The following options are available:

Certificate of Calibration Extended cable

INSTALLATION

The installation process consists of the following stages:

Preparation Mechanical installation Electrical installation

Please read the following sections thoroughly before proceeding with the installation.

PREPARATION

Ensure that the sensor is positioned so that it is focused on the target only.

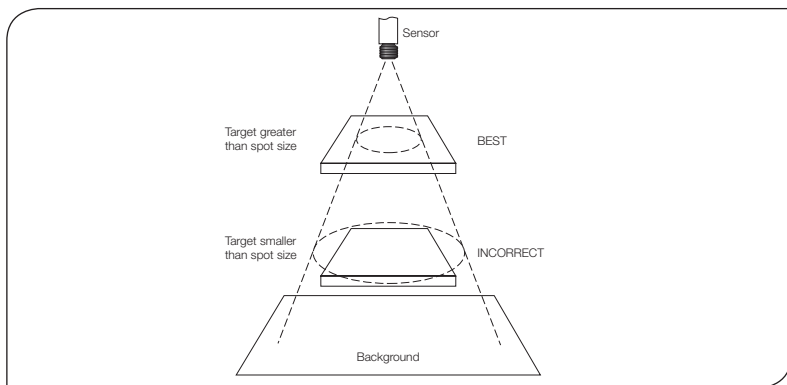

OPTICAL CHART

The sensor may be used at longer distances than shown, and will measure a larger spot. The measurement accuracy is not affected by the measurement distance.

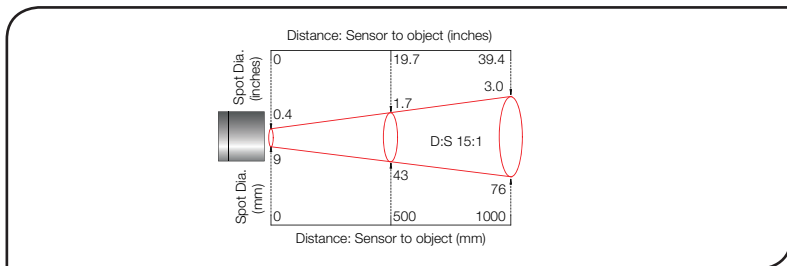

DISTANCE AND SPOT SIZE

The size of the area to be measured (spot size) determines the distance between the sensor and the target. The spot size must not be larger than the target. The sensor should be mounted so that the measured spot size is smaller than the target.

AMBIENT TEMPERATURE

The sensor is designed to operate in ambient temperatures from 0°C to 80°C.

Avoid thermal shock. Allow 20 minutes for the unit to adjust to large changes in ambient temperature.

ATMOSPHERIC QUALITY

Smoke, fumes or dust can contaminate the lens and cause errors in temperature measurement. In these types of environment, the air purge collar should be used to help keep the lens clean.

ELECTRICAL INTERFERENCE

To minimise electromagnetic interference or 'noise', the sensor should be mounted away from motors, generators and such like.

WIRING

Check the distance between the sensor and the measurement instrumentation. If necessary, the sensor can be ordered with a longer cable attached.

POWER SUPPLY

Check the supply voltage is between 6 V DC and 28 V DC.

To use the 0-10 V output, the supply voltage must be at least 12 V DC.

IMPORTANT: Ensure the power supply is only connected to the PWR+ and PWR- wires, and the polarity is correct, before switching the power on.

Do not switch the power off and on again quickly. If the power is switched off, allow 15 seconds before switching it back on.

MECHANICAL INSTALLATION

All sensors come with a 1 metre cable and two mounting screws. The sensor can be mounted on brackets or cut-outs of your own design, or you can use the fixed and adjustable mounting bracket accessories which are shown below.

The supplied mounting screws are for use with a panel or bracket at least 2 mm thick. The screws are 8 mm long.

Between the mounting holes, there must be a hole to allow the sensor a clear view through the panel or bracket. This hole must be larger than the lens of the sensor or the aperture of the air purge, if used. Use as large a hole as possible.

Note: The sensor must be grounded at only one point, either the cable shield or the mounting screws, but not both.

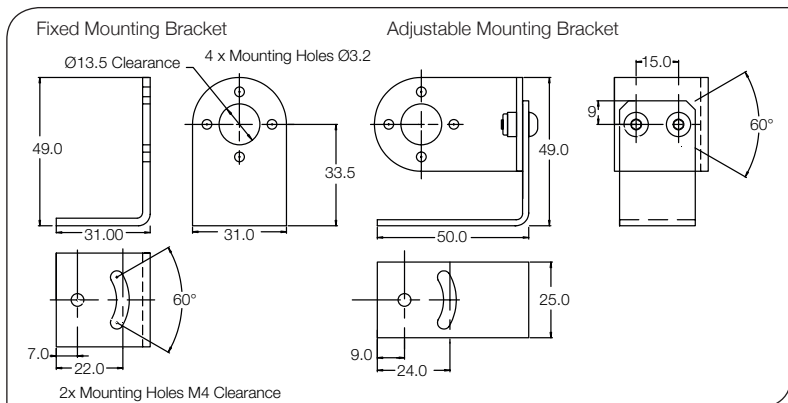

AIR PURGE COLLAR

The air purge collar is used to keep dust, fumes, moisture, and other contaminants away from the lens. It fits between the sensor and the mounting surface. Longer screws are provided for use with a panel or bracket at least 2 mm thick.

Air flows into the hose barb fitting and out of the front aperture. Air flow should be 5 to 15 litres/min.

Clean or 'instrument' air is recommended.

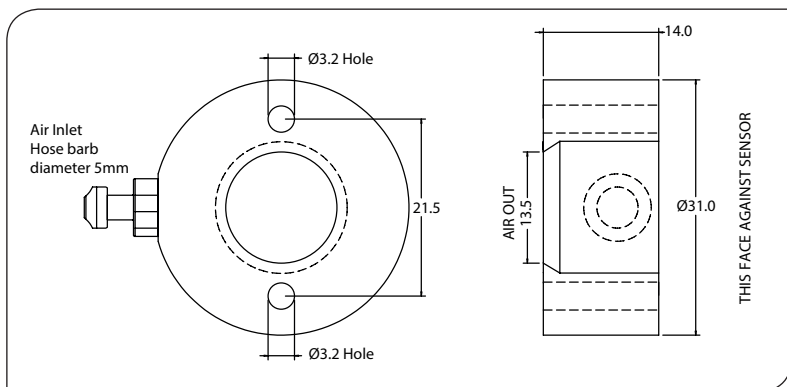

ELECTRICAL INSTALLATION AND DIMENSIONS

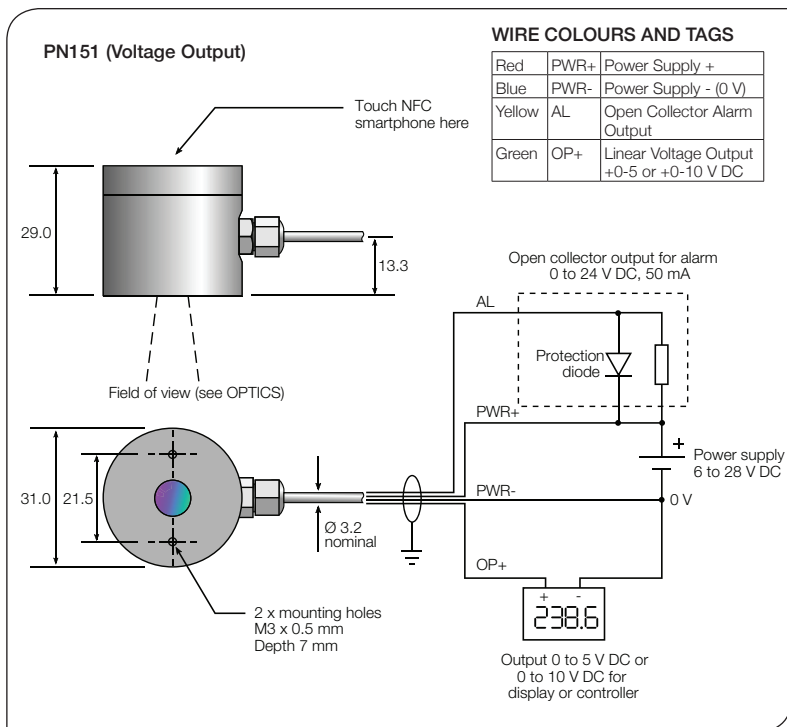

PN151-K (Thermocouple Output)

WIRE COLOURS AND TAGS

Red	PWR+	Power Supply +
Blue	PWR-	Power Supply -
Purple	OP-	Type K output -
Green	OP+	Type K output +
Yellow	AL	Alarm output

If you extend the Type K output wires, ensure Type K thermocouple cable and connectors are used. Using copper or other metals will affect the accuracy of the measurement.

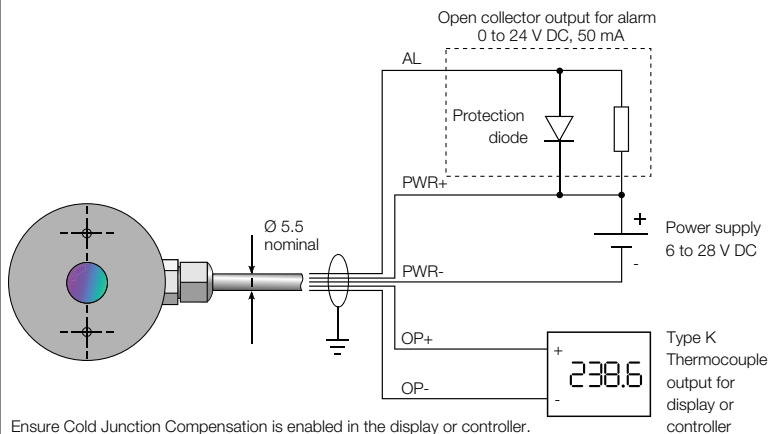

Caution! Check the identification tags and ensure wiring is correct before applying power to the sensor.

OPERATION

Once the sensor is in position and the appropriate power, air and cable connections are secure, the system is ready for continuous operation by completing the following simple steps:

1. Turn on the power supply
2. Turn on the measurement instrument
3. Read / monitor the temperature

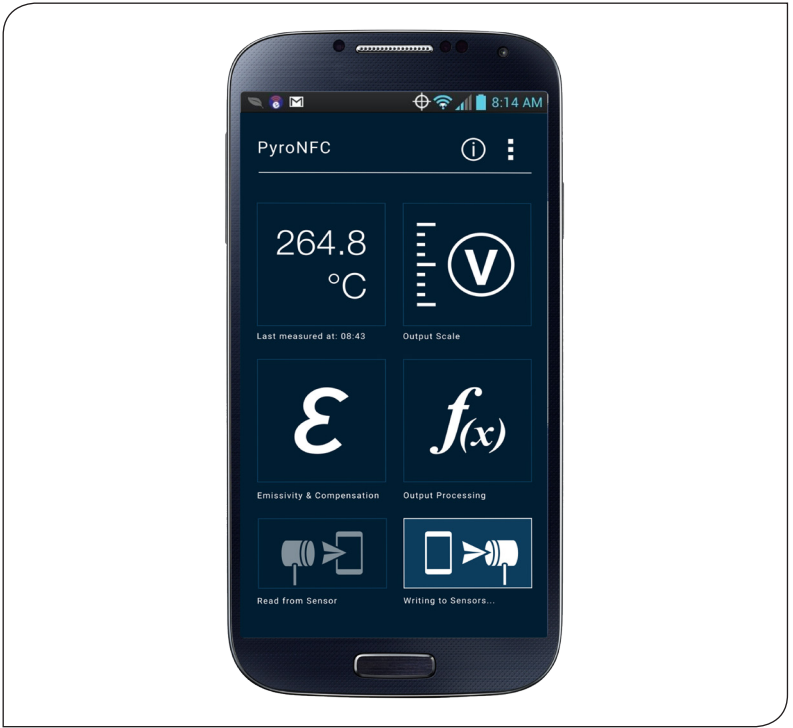

CONFIGURATION AND READING TEMPERATURES

The sensor is fully configurable via a smartphone or tablet with NFC capability. Download the free app for Android devices from the Google Play Store.

Touch the NFC device against the back of the sensor to read the measured temperature. The reading updates continuously while the phone is touching the sensor.

The sensor must be powered to read the measured temperature with the app.

Edit the configuration parameters in the app, then tap "Write to Sensor". Touch the NFC device against the back of the sensor to write the settings. A message will appear on the device to confirm the settings have been written successfully.

Allow at least 5 seconds for the new settings to take effect.

There is no need to power the sensor to read or write the settings.

CONFIGURATION (MODEL PN151K):

The Type K thermocouple output has a temperature range of 0 to 1000°C. This is not rescalable.

The settings in the app for configuring the voltage output type and scale on models with linear

voltage output have no effect on PyroNFC-K models with Type K thermocouple output. Select the correct sensor model from the drop-down list in the app to hide these options.

IMPORTANT

Be aware of the following when using the sensor:

- If the sensor is exposed to significant changes in ambient temperature (hot to cold, or cold to hot), allow 20 minutes for the temperature to stabilise before taking or recording measurements.
- Do not operate the sensor near large electromagnetic fields (e.g. around arc welders or induction heaters). Electromagnetic interference can cause measurement errors.
- Wires must be connected only to the appropriate terminals.
- Ensure the sensor is grounded at one point: either the cable shield termination, or the mounting screws, but not both.
- When the power is switched off, allow at least 15 seconds before switching the power back on.

MAINTENANCE

Our customer service representatives are available for application assistance, calibration, repair, and solutions to specific problems. Contact our Service Department before returning any equipment. In many cases, problems can be solved over the telephone. If the sensor is not performing as it should, try to match the symptom below to the problem. If the table does not help, call Calex for further advice.

Troubleshooting		
Symptom	Probable Cause	Solution
No output	No power to sensor	Check power supply
Erroneous temperature	Incorrect wire connection	Check wire colour codes
Erroneous temperature	Faulty sensor cable	Verify cable continuity
Erroneous temperature	Field of view obstruction	Remove obstruction

LENS CLEANING

Keep the lens clean at all times. Any foreign matter on the lens would affect measurement accuracy. Blow off loose particles (if not using the air purge accessory) with an air 'puffer'.

DEFAULT SETTINGS

The PyroNFC is fully configurable via an Android app. No configuration is necessary: the sensor will work straight out of the box using the below default settings.

All settings are adjustable except those marked *(fixed)*.

Sensor Model		PN151	PN151-K
Output Voltage	(0-5 V / 1-5 V / 0-10 V)	0-10 V	<i>Type K Thermocouple (fixed)</i>
Temperature Low		0°C	0°C <i>(fixed)</i>
Temperature High		1000°C	1000°C <i>(fixed)</i>
Alarm Trigger	(High / Low / Off)	High	High
Alarm Monitor Temperature	(Target / Internal)	Target	Target
Alarm Set Point		30°C	30°C
Alarm Hysteresis		1°C	1°C
Alarm Mode	(Active High / Active Low)	Active High	Active High
Alarm Reset	(Auto / Manual)	Automatic	Automatic
Emissivity Setting		0.95	0.95
Reflected Energy Compensation	(On / Off)	Off	Off
Reflected Temperature		25°C	25°C
Averaging Period		125 ms	125 ms
Hold Mode	(Peak / Valley / Off)	Off	Off
Hold Period		250 ms	250 ms

GUARANTEE

Calex guarantees each instrument it manufactures to be free from defect in material and workmanship under normal use and service for the period of two years from the date of purchase. This guarantee extends only to the original buyer according to Calex's Terms and Conditions of Sale.

Calex Electronics Limited

PO Box 2, Leighton Buzzard, Bedfordshire, England LU7 4AZ

Tel: +44 (0)1525 373178 Fax: +44 (0)1525 851319

Email: mail@calex.co.uk Online: <http://www.calex.co.uk>