

CALEX

ELECTRONICS LIMITED

VL 700

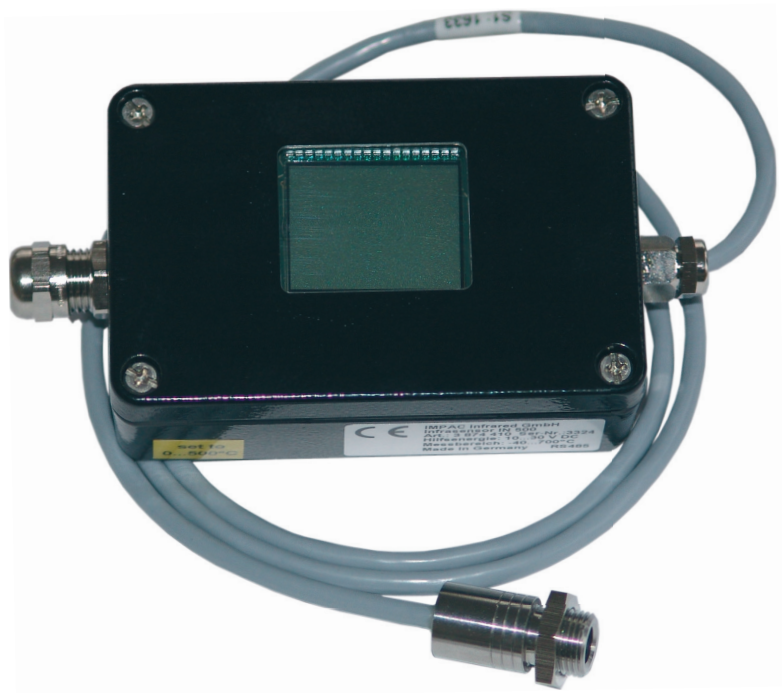

User Manual

Contents

1	General	3
1.1	Information to the user manual	3
1.2	Limit of liability and warranty	3
1.3	Disposal	3
1.4	Scope of delivery	4
1.5	Sensor head	4
1.6	Important notes	4
2	Technical data	5/6
3	Switching on	6
3.1	Mechanical installation	6
3.2	Electrical installation	7/8
4	Description of the parameters	9/10/11
5	Parameter settings	12
6	Settings via interface and software	12/13
7	Exchange of sensor head	13
8	Alarm messages at non-specified sensor head temperatures	13
9	Data format UPP® (Universal Pyrometer Protocol)	13/14/15
10	Reference numbers for instrument	16
11	Accessories	16
12	Copyright	16

1 General

1.1 Information to the user manual

Congratulations on choosing the high quality and highly efficient CALEX pyrometer. The VL 700 is a digital pyrometers for non-contact temperature measurement of non-metallic surfaces or coated (painted) metallic surfaces. The infrared radiation of one spot of the object is shown on the detector inside the sensor head and converted into electrical signal. This signal will be linearized in the electronic box and converted into standard analog and digital outputs, and displayed on an LCD.

Please read this manual carefully before installing this pyrometer. It contains all the necessary information to set up and operate the new CALEX pyrometer.

Should you require further assistance, please call our customer service hotline in Leighton Buzzard, England : 0044 (0) 1525 373178.

1.2 Limit of liability and warranty

All general information and notes for handling, maintenance and cleaning of this instrument occurs to the best of our knowledge under consideration of our know-how. CALEX is not liable for any damages that arise from the use of any examples or processes mentioned in this manual or in case the content of this document should be incomplete or incorrect. CALEX reserves the right to revise this document and to make changes from time to time in the content here of without obligation to notify any person or persons of such revisions or changes.

The VL 700 instruments from CALEX have a warranty of two years from the invoice date. This warranty covers manufacturing defects and faults which arise during operation only if they are the result of defects caused by CALEX. This warranty is void if the instrument is disassembled, tampered with, altered or otherwise damaged, without prior written consent from CALEX.



1.3 Disposal (in accordance with RL2002/96/EC)



The unit may not be disposed of with normal household waste but must disposed of in accordance with environmental regulations.

1.4 Scope of delivery

Device with sensor head 10 : 1, RS485-interface, 3 m or 15 m Sensor cable

1.5 Sensor head

According to requirements the instrument will be delivered with one of the below mentioned sensor heads. The pyrometer can measure objects at any distance but the farther the distance, the larger is the measuring area (spot size). The object has to be bigger or at least as big as the spot size of the pyrometer in the measuring distance.

The following drawings show the pyrometer's spot sizes in different measuring distances. The spot size at a distance of $a = 0$ mm is $M = 5$ mm and corresponds to the aperture of the sensor head.

The sensor head is changeable. For the adaptation to the electronic an 8-digit pin-code has to be set (see page 29: change of sensor head).

sensor head 10:1
(3 marking rings)

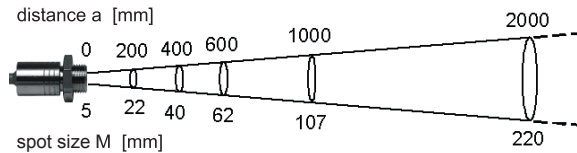

head with close focus lens
10:1

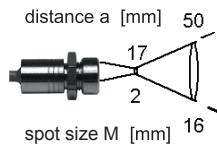

1.6 Important notes

Maintenance

The pyrometer has no internal parts, which have to be serviced. The lens can be cleaned with compressed air, which is dry and free of oil. If the lens requires more thorough cleaning, use a soft, dry cloth such as that used to clean camera lenses.

Caution: Do not clean or touch the lens with acids or solvents!

The Ge lens of the 10 : 1 sensor head has an anti-reflective coating which appears slightly colored. Be careful cleaning the lens as this layer can be rubbed off what will greatly affect the measuring results!

Uncertainty ***) Dependent on object temperature T and ambient temperature Tamb. (EMI = 1, t90 = 1 s):	$\frac{T}{T_{amb}}$	15...30°C	0...15°C or 30...65°C	65...85°C
	0...300°C	1% of measured value in °C or 1°C *)	1,2% of measured value in °C or 1.5°C *)	1,5% of measured value in °C or 2°C
	300...700°C	1% of measured value in °C	1,5% of measured value in °C	1,8% of measured value in C
	-40...0°C	2°C	3°C	- **)
	*) Whichever value is greater. The instrument must be at a constant ambient temperature for a minimum of 15 minutes **) difference between sensor head temp. and object temp max. 85°C ***) With thermocouple output minimum 2.5°C			
Ambient temperature sensor head:	0 ... 85°C 0 ... 200°C with cooling and air purging accessories			
Storage temperature sensor head:	-20 ... 85 °C			
Relative humidity:	10 ... 95%, non condensing			
Protection class:	IP65 (Converter, Sensor head 10 : 1)			
Weight:	320 g			
Dimensions:	Converter: 98 mm x 64 mm x 34 mm (L x B x H) Sensor head: 28 x 14 mm (l x Ø), thread M12 x 1, l=10.8 mm			
Housing:	Aluminium (converter), stainless steel (sensor head)			
Operating position:	Any			
CE Approval / EMV tests:	According to EU directives about electromagnetic immunity			

3 Switching on

3.1 Mechanical installation

Two mounting holes are provided under the cover of the electronic box.

To fix the optical heads (or the air purges) mounting angles are available for optimal alignment at the measuring object.

Electronic box

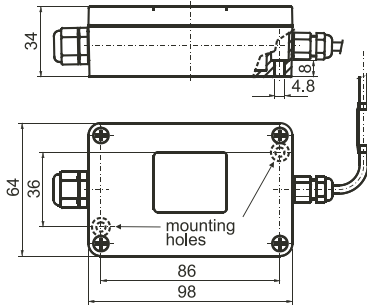

Sensor-head 10:1

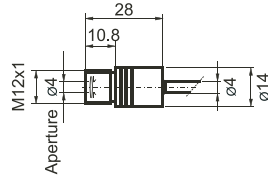

3.2 Electrical installation

The VL 700 is supplied by 10 ... 30 V DC.

To meet the electromagnetic requirements (EMV), a shielded connecting cable must be used. The shield of the connecting cable (diameter: 3 - 6.5 mm) has to be connected only on the pyrometer side to avoid ground loops.

Connection signal output and power supply

Connection sensor head

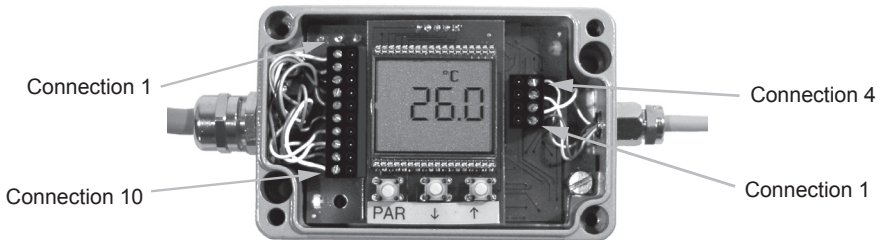

The Connection

1	Relay contact (isolated)	(pink)	The sensor head is already connected to the converter (state of delivery).
2	Relay contact (isolated)	(grey)	
3	RS232 interface TxD (RS485 „B“)	(violet)	
4	RS232 interface DGND	(red)	
5	RS232 interface RxD (RS485 „A“)	(black)	
6	Sensor head temp. (connection to GND)	(blue)	
7	Analog output mA or V or type K or type J (connection to GND)	(green)	
8	GND (- OUT)	(yellow)	
9	0 V	(brown)	
10	10 ... +30 V DC	(white)	
4	NTC resistor	(yellow)	
3	NTC resistor	(green)	
2	Thermopile (+)	(white)	
1	Thermopile (-)	(brown)	

The connection cable

The connecting cable has to be selected according to the following criteria:

1. Shielded
2. Diameter 3 - 6.5 mm
3. Quantity of wires: if necessary 2 to 10:
 - 2 for power supply additionally, if required:
 - 1 for analog output
 - 1 for sensor head temperature
 - 1 GND for analogue output and / or sensor head temperature
 - 3 for digital interface
 - 2 for relay contact

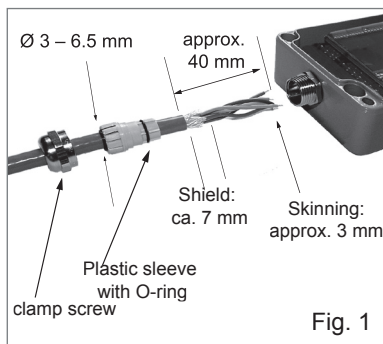

The connection

1. Preparation of the cable in accordance with **Fig. 1**.
2. The shielding of the connecting cable has to be pushed over the plastic sleeve 2 mm further than the O-ring.
3. Fix the cable with the clamp crew.
4. At state of delivery an internal connection between contact 9 and the housing exists. Should the housing have its own earth potential caused by an electric connection to an object, the internal connection has to be removed.

The screw bars inside the converter can be lifted up for easy installation of the wires (input/output cables and sensor head) **Fig. 2**.

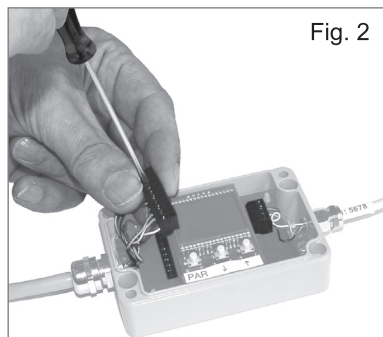

Caution: Before connecting the VL 700 to further instruments (e.g. controller, PLC, etc.) the correct analog output (current, voltage or thermocouple), corresponding to the input of the instrument, has to be adjusted at the converter. A wrong output might damage the connected instrument.

Fig. 3 : For mounting of the converter housing there are two holes for 4 mm screws.

After mounting, connecting of cables and parametrizing (if necessary) close the cover of the converter and tighten the 4 screws.

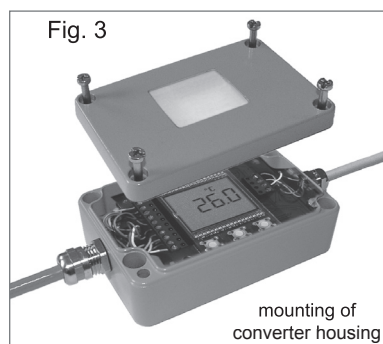

Note: If using the VL 700 with measuring output thermocouple type K or J, this output has to be connected with the correct compensating cable.

4 Description of the parameters

The setting of the parameters of the **VL 700** can be done serial interface (PC) (see page 27), or additionally by integrated push buttons inside the converter (see page 26, parameter settings).

Emissivity (EMI)

The emission coefficient (emissivity) is the relationship of the emission output of an object to the emission output of a black body radiation source (this is an object which absorbs all incoming rays, EMI = 100%) at the same temperature. Different materials have different emissivities ranging between 0% and 100% (settings at the pyrometer are 10 ... 100%, an additional attenuation, setting from 100 to 120% can be used for example to correct the measurement of objects behind gases with hot soot). Materials which reflect more radiation have a lower emissivity and the emissivity setting of the pyrometer needs to be adjusted accordingly. Emissivity values of various common materials are listed below:

Object	Emissivity (%)
„ Black body furnace „	100
Human skin	98
Black dull varnish	95
Carbon soot	95
Wood	80 ... 92
Paper	92 ... 95
Asphalt	85
Glass / Quartz glass	72 ... 87
Textile	75 ... 95
Graphite	75 ... 92
Cement	90
Water	95

Object	Emissivity (%)
Fire clay	85 ... 95
Rubber	85 ... 95
Porcelain	85 ... 95
Ceramics	85 ... 95
Varnish	85 ... 95
Plaste	85 ... 95
Oil paint	85 ... 95
Brickwork	85 ... 95
Steel (smooth)	10 ... 30
Aluminium (smooth)	2 ... 15
Aluminium (anodized)	90
Steel (oxidized)	60 ... 80)

Response time (T₉₀)

The response time is the time interval between the instant of an abrupt change in the value of the measuring temperature and the instant from which the measured value of the pyrometer remains within specified limits. The time is taken to reach 90 % of the recorded temperature difference. In the OFF position, the device operates using his time constant (shortest response time). Longer response times can be used for the measurement of objects which have rapidly fluctuating temperatures to achieve constant temperature reading.

Settings:
OFF
0.5 s
.
.
30 s

Clear time (TCL)

The maximum value storage (or minimum value storage) stores the highest (or lowest) measurement value. The clear time defines the time period until the stored value is deleted and replaced by a new one.

The following settings are possible:

- Clear time "OFF": The storage is switched off and only momentary values are measured. If any clear time TCL is set either the maximum value or minimum value storage will be cleared.
- The "auto" mode is used for discontinuous measuring tasks. For example objects are transported on a conveyer belt and pass the measuring beam of the pyrometer only for a few seconds. Here the maximum (minimum) value for each object has to be indicated.

Settings:
OFF
0.1 s
.
.
25 s
extern
auto

- In this mode the maximum (minimum) value is stored until a new hot (or cold) object appears in the measuring beam. The temperature which has to be recognized as “hot“ (or “cold“) is defined by the low (high) limit of the adjusted sub range. The stored maximum value will be deleted when the temperature of the new hot object exceeds the low limit LO of the sub range by 1% or at least 2°C. The stored minimum value will be deleted when the object temperature falls below the high limit HI of the sub range by 1% or at least 2°C.
- The external clearing (“extern“) of the storage can only be activated and used with an own software (see data format UPP®, page 28).

Selection of the maximum or minimum value storage (MAX or MIN)

With this setting you choose between maximum or minimum value storage if the storage function is activated by setting TCL. If TCL is switched “OFF“, the storage function is not activated, the indication of “MAX“ or “MIN“ only shows the preselection.

Settings:
MAX
MIN

Subrange (LO / HI)

You have the opportunity to choose a subrange (minimum 51°C) within the basic measuring range of the pyrometer. This subrange corresponds to the analog output. LO describes the beginning of this measuring range, HI the end of the range. If the thermocouple output is used, the analog output does not change. Additionally with the setting of a subrange it is possible to fulfil the requirements of the “auto“ clear mode of the maximum or minimum value storage (see above).

Settings:
700°C
.
.
.
-40°C

Analog output (OUT)

The analog output has to be selected according to the signal input of the connected instrument (controller, PLC, etc.). You can choose between current output (0 or 4 to 20 mA), voltage output (0 to 5 V) or thermocouple output type J or K.

Settings:
0-20 mA
4-20 mA
0-5 V
Typ J
Typ K

Caution: Before connecting the VL 700 to further instruments (e.g. controller, PLC, etc.) the correct analog output (current, voltage or thermocouple), corresponding to the input of the instrument, has to be adjusted in the converter. A wrong output might damage the connected instrument.

Temperature display (°C / °F)

The temperature can be displayed in °C or °F.

Settings:
°C
°F

Compensation of ambient temperature (CMP)

This compensation is used for a very few special applications only. The standard setting of this parameter is “auto“, because the temperature of the sensor head is normally the ambient temperature of the measured object. Should the measured object be placed in an area with a higher ambient temperature (e.g. inside a furnace), the measurement might be falsified (probably too high temperature indication). This influence can be compensated by presetting of the ambient temperature of the object with help of the CMP-function (presetting within the measuring range of the instrument). It has to be considered, that this method only improves the results if the ambient temperature at the place of the measured object is always constant.

Settings:
700°C
.
.
.
-40°C
auto

Sensor head temperature (AMB)

The temperature of the sensor head can be displayed.

Baud rate (BD)

The transmission rate of the serial interface in Baud (Bd) is dependent on the length of the cable. The standard cable length with RS485 for 19200 Bd is 2 km. The baud rate is reduced by 50% if the transmission distance is doubled.

Settings:
19200 Bd
.
.
1200 Bd

Address (AD)

For the connecting of several pyrometers with RS485 (up to 32) with one serial interface it is necessary to give each instrument an individual address for communication. First it is necessary to connect each single instrument to give it an address. After that all instruments can be connected and addressed individually. If parameters may be changed simultaneously on all pyrometers, the global Address 98 can be used. This allows you to program all pyrometers at the same time, regardless of the addresses that have already been assigned. If the address of a pyrometer is unknown, it is possible to communicate with it using the global Address 99 (connect only one pyrometer).

Settings:
31
.
.
00

Limit switch (LIM)

The instruments are equipped with an relay contact, controlled by the measuring signal. The switch point of this relay is adjustable with the function "LIM" within the measuring range. The relay contact is closed below the adjusted value, it is open above it.

Settings:
700°C
.
.
-40°C

Hysteresis (HYS)

The relay contact opens immediately when the temperature exceeds the adjusted "LIM" value, it closes only if the temperature falls below a value which consists of "LIM" and the adjusted hysteresis.

Settings:
20°C
.
.
2°C

5 Parameter settings

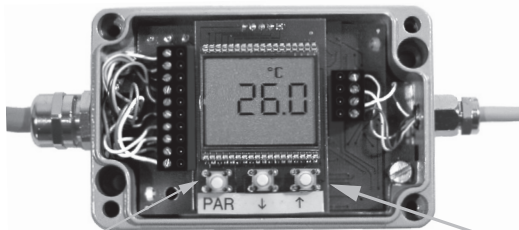

The buttons for parametrizing the VL 700 are inside the converter and are accessible after removing the cover (4 screws).

Note: Do not operate the converter permanently with open cover.

Selection of parameters: the parameters are called with the button **PAR** (the sequence is described on pages 24 - 26). If no button is pushed for approx. 15 s, the instrument switches back to measuring mode with the latest parameter settings. A changed value of a parameter is automatically stored after changing to another parameter.

Up / down buttons (↑ ↓): After selection of one parameter with the PAR button the up / down buttons are used to set the available values.

7 Exchange of sensor head

The sensor head is exchangeable for example if a sensor head with other optical data or a longer cable is needed.

The cable has to be prepared in accordance with opposite illustration. Push the shield above the washer and O-rings, put the cable through the hole and connect the wires to the screw bar (connecting scheme on page 23). Fix the cable with the clamp screw at the housing.

Each sensor head cable is equipped with a label with codes which has to be set in the pyrometer:

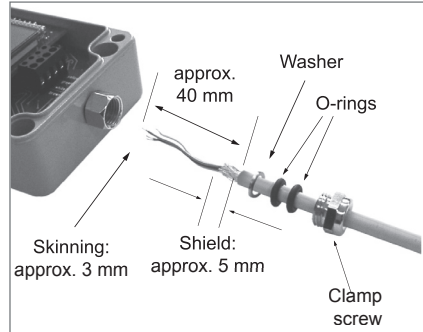

- Setting via software: Set these codes S1 and S2 in **“pyrometer parameter”** under the button Exchange sensor head and confirm them with **“OK”**. Now the new sensor head is matching to the converter and the pyrometer is ready for measuring.

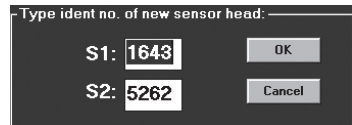

- Additionally in the VL 700 the setting of the sensor head codes can be done via internal push buttons: Remove the cover of the converter and press the buttons [↑] and [↓] simultaneously. While pressing these two buttons push the **“PAR”** button too. The display shows code S1.
- With the arrow buttons [↑] and [↓] the new code S1 has to be set and confirmed with the **“PAR”** button. Now code S2 appears on the display and has to be set and confirmed in the same way.

8 Alarm messages at non-specified sensor head temperatures

The pyrometer gives the following alarm messages for the protection of the electronic and the machines if the temperature of the sensor head exceeds or falls below the specified values:

- Excess of specified sensor head temperature (85 °C):
 - Output of the serial interface code 75550
 - Output of the analog output: 22 mA at 0/4 .. 20 mA, 5 V at 0 ... 5 V, excess of end of measuring range at thermocouple output
 - The relay is de-energized (contact open)
 - Display of VL 700: ERR 1 instead of the temperature reading
- Sensor head temperature falls below specified value (0 °C):
 - Output of the serial interface code 74440
 - Output of the analog output: 22 mA at 0/4 .. 20 mA, 5 V at 0 ... 5 V, excess of end of measuring range at thermocouple output
 - The relay is de-energized (contact open)
 - Display of VL 700: ERR 2 instead of the temperature reading

There is no alarm message if the converter temperature runs out of its specified operating temperature.

9 Data format UPP® (Universal Pyrometer Protocol)

The data exchange occurs in ASCII format with the following transmission parameters:

The data format is: 8 data bits, 1 stop bit, even parity (8,1,e)

The device responds with the entry of a command with: output (e.g. the measuring value) + CR (Carriage Return, ASCII 13), with pure entry commands with „ok“ + CR. With invalid commands the instruments answers with „no“ + CR.

Every command starts with the 2-digit device address AA (e.g. „00“). This is followed by 2 small command letters (e.g. „em“ for level of emissivity ϵ), finished with CR
 This is followed, if necessary for that command, by the ASCII parameter „X“. If this parameter „X“ is omitted, then the device resets with the current parameter.

Example: Entry: "00em" + <CR>

The emissivity setting (ϵ) of the device with the address 00 is returned

Answer: "0970" + <CR> means emissivity = 0.970

Setting emissivity:	AAemXXXX	XXXX = 0100 ... 1200 in %
Reading emissivity:	AAem	Output: 0100 ... 1200 in %
Response time t ₉₀ :	AAezX	X = 0 ... 6 (decimal) 0 = intrinsic time constant of the device 1 = 0.5 s 2 = 1 s 3 = 2 s 4 = 5 s 5 = 10 s 6 = 30 s
Setting clear time tCL:	AAIzX	X = 0 ... 8 (decimal) 0 = Max. value- / min. value storage off 1 = 0.10 s 5 = 5.00 s 2 = 0.25 s 6 = 25.00 s 3 = 0.50 s 7 = external clearing 4 = 1.00 s 8 = automatic clearing
External clearing:	AAIx	Simulation of an external reset contact
Analog output 1):	AAasX	X = 0 ... 4 2 = 0 ... 5 V 0 = 0 ... 20 mA 3 = thermocouple type K 1 = 4 ... 20 mA 4 = thermocouple type J
Reading measuring value:	AAms	Output: YYYYY; 5-digit decimal, in 1/10 °C or °F 88880 = temperature-overflow 75550 = exceed max. sensor head temp. 74440 = fall below min. sensor head temp. 02563 = 256.3 °C or °F; -0170 = -17.0 °C or °F
repeatedly reading measuring values:	AAmsXXX	XXX = 000 ... 999 XXX = Number of measuring values
Temperature 1):	AAfhX	X = 0;1 0 = Output Celsius 1 = Output Fahrenheit
Serial number:	AASsn	Output: XXXXX (5-digit decimal)
Reading basic measuring range:	AAmb	Output: YYYYYZZZ (8-digit hex) 2) YYYYY = beginning of measuring range ZZZZ = end of measuring range
Setting sub range:	AAmeYYYYZZZZ	YYYY = beginning of measuring range ZZZZ = end of measuring range
Reading sub range:	AAme	as with mb
Sensor head temp.:	AAgt	Output: XX (dez. 00 ... 99 in °C)
Reset 1):	AAre	Reset device
Reading switch point:	AAsl	Output: XXXX (4-digit hex) 2)
Reading sensor data:	AAse	Output: XXXXXXXY (8-digit decimal); Reading of adjusted sensor data: XXXX: S1; YYYY: S2
Entering ambient temp.:	AAutXXXX	XXXX = Value of ambient temp., 4-digit hex 2)
Reading ambient temp.e:	AAut	Output: stored value, 4-digit hex 2) e.g. 0258 corresponds to 600 degrees

Max. sensor head temp.:	AAtm	Output: XX (dez. 00 ... 99 in °C)
Error status:	AAfs	Output 1 byte hex; Bit 0 = 1: EEPROM error Bit 1 = 1: watch dog reset Bit 2 = 1: low voltage reset
Type / Software version:	AAve	Output: XYYZZ (6-digit decimal) XX = 75 (IN 500); YY = Month of software version ZZ = Year of software version
Reading parameters:	AApa	Output 11-digit decimal: Digit 1 and 2 (10...99 or 00): EMI up to 100 Digit 3 (0 ... 6): t ₉₀ (response time) Digit 4 (0 ... 8): t _{CL} (storage clear mode) Digit 5 (0 / 4): analog output Digit 6 and 7 (00 ... 99): sensor head temp. Digit 8 and 9 (00 ... 31): device address Digit 10 (0 ... 4): device baud rate Digit 11 (always 0)
Changing device address 1):	AAgaXX	XX: device address decimal; 00 ... 31 variable device addresses; global: 98, 99
Changing baud rate:	AAbrX	X = 0 ... 4 0: 1200 bd 1: 2400 bd 2: 4800 bd 3: 9600 bd 4: 19200 bd
Command delay:	AAtwXX	XX = 00 ... 20 relative delay value
Setting switch point:	AAslXXXX	XXXX (4-digit hex) 2); adjustable within sub range
Setting hysteresis:	AAhl	Output: XX (2-digit hex) 2)
Reading hysteresis:	AAhlXX	XX (2-digit hex) 2); XX setting 2 ... 20°C (4 ... 36°F)
Setting sensor data:	AAseXXXXXXXX	XXXXXXXX (8- digit dec.); entering sensor data
Read. max/min value:	AAmi	Output: 0 or 1; 0 = max value, 1 = min value

Note: - the letter "l" means the small type of "L"; - bold values = default settings

- 1) After entering these commands the device carries out an automatic reset. The device needs approx. 150 ms before it is ready to use and work with the changed settings.
- 2) The input and output corresponds to the preset degree C or degree F.

Response times at 19200 Baud

The times are measured between the end of enquiry and the end of the answer.

At least minimum 50 measurements were done in each setting.

1. Reading parameters tw = 00 0.5 ... 1.3 ms tw = 05 5.5 ... 6.5 ms
tw = 01 1.3 ... 2.5 ms tw = 10 11.5 ... 13 ms
tw = 02 2.2 ... 3.2 ms
2. Changing parameters approx. 6 ... 8 ms longer than 1. caused by EEPROM-writing
3. Command ms tw = 00 1.0 ... 6.5 ms
tw = 01 2.3 ... 7.8 ms
tw = 05 7.5 ... 15.5 ms
duration of reading (xms<CR> = 5 ASCII signs) 3.0 ms
duration of response (xxxx<CR> = 6 ASCII signs) 3.6 ms

Additional instruction for the RS485 interface

Requirements to the master system during half-duplex operation:

1. After an inquiry, the bus should be switched into a transmission time of 3 bits (some older interfaces are not fast enough for this).
2. The pyrometer's response will follow after 5 ms at the latest.
3. If there is no response, there is a parity or syntax error and the inquiry has to be repeated.

After receiving the response, the master has to wait at least 1.5 ms before a new command can be entered.

10 Reference numbers for instruments

VL 700: INVL 700

11 Accessories

Numerous accessories guarantee easy installation of the pyrometers. The following overview shows a selection of suitable accessories.



Connecting cable with additional digital cable



Air purge for sensor head 10:1 (not with close-up lens)



Mounting angle for sensor head

Standard settings at delivery:

EMI=100; T90=OFF; TCL=OFF; MAX/MIN=MAX; OUT=0...20 mA; LO=0°C; HI=500°C; °C/°F=°C; CMP=auto; BD=19200; AD=00; LIM=0°C; HYS=2°C

Packing instructions

To transport or store the instrument, please use the original box or a box padded with sufficient shock-absorbing material. For storage in humid areas or shipment overseas, the device should be placed in welded foil (ideally along with silicon gel) to protect it from humidity.

12 Copyright

All copyrights reserved. This document may not be copied or published, in part or completely, without the prior written permission of CALEX Electronics Limited.

Contraventions are liable to prosecution and compensation.

All right reserved practicing industrial property rights.

CALEX Electronics Limited
PO Box 2
Harrmill Industria Estate
Leighton Buzzard,
Bedfordshire, England
LU7 4AZ

Tel.: 0044 (0) 1525 373178
Fax: 0044 (0) 1525 851319
EMail: info@calex.co.uk
Web: <http://www.calex.co.uk>